

T T P

The Technology Partnership Plc

**Technology innovation and product
engineering for inkjet**

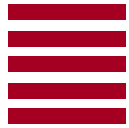

The Technology Partnership - TTP

Since its founding in 1987, TTP has grown to become Europe's leading independent technology innovation and product development organisation.

TTP has extensive laboratory and pre-production manufacturing facilities along with over 250 graduate engineers and scientists drawn from a broad range of technology and industry backgrounds.

TTP has in-depth experience of undertaking new product development with leading global companies in a range of industries including:

- Printing
- Radio Communications
- Consumer
- Medical and healthcare
- Industrial and automotive

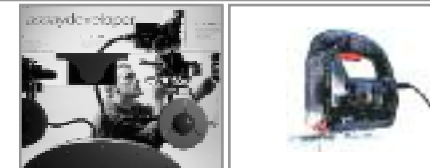

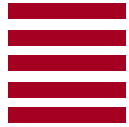

Skill Set - overview

All the skills required to offer comprehensive contract-based development to help you develop your new technology, design your new product and get it into manufacture

Mechanical Engineering

- 3D CAD
- Stress/fatigue analysis
- Fluid handling (dispense, cooling, pumping)
- Media handling (web, sheet, other shapes)
- Manufacturing processes
- Materials expertise

Electrical/Electronic Engineering

- RF design
- Power electronics and control
- Wired/wireless Communication
- Signal processing
- Vision systems
- ASIC/FPGA/IPM

Project Management

- Concept generation
- Design evaluation
- Supplier selection
- Prototype manufacture and Testing
- Production transfer
- Industrial design

Software Engineering

- Large system development
- Micro,DSP
- ASM, C, C++
- Embedded software
- Real time operating systems

Physics & Chemistry

- Inkjet
- Laser/Optics
- Micro fluidics & structures
- Mathematical modelling
- Ink
- Liquid toners

Technology Management

- IP portfolio management
- Technology sourcing
- Business case development
- Project management
- Off-shoring manufacture strategy
- Venture Capital

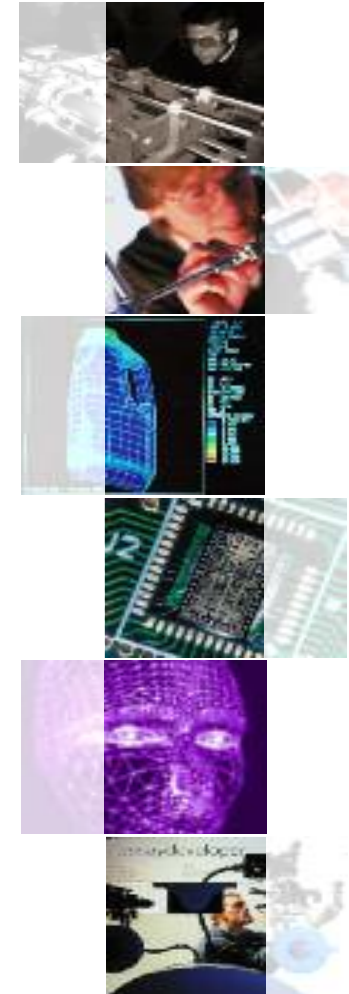



TTP & Inkjet

- Printer Development
 - *Complementing our client's engineering resources to introduce inkjet to their product portfolio or to speed up time-to-market*
- Consulting
 - *Broad technology studies*
 - *Manufacturing Strategy*
 - *Market, business and Intellectual Property strategy*
- Inkjet component design
 - *Sub-systems and components to facilitate inkjet printer developments*
- Custom printing system development
 - *Bespoke designs for unique applications*
 - *Industrial and Commercial inkjet equipment*
- Novel print technology development
 - *Doing what inkjet can't do.*
 - *Improving on what inkjet can do.*
- Printer re-design for cost reduction and/or transfer to Asian manufacture
 - *Complementing our client's engineering resources to improve existing product lines*

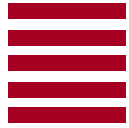

Inkjet Printer for Postage Franking

- Neopost IJ25

- TTP tasks
 - Printhead and manufacturer selection
 - System design and project planning
 - Detail design for mechanics, electronics, and print engine firmware
 - Prototype assembly and testing
 - Production transfer
 - Production support



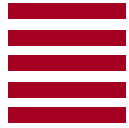

Cost reduction of an inkjet proof printer

- Stork AX4 / Du Pont Cromalin

- TTP tasks
 - Initial analysis of cost reduction opportunity
 - Detailed study into cost reduction options from new architecture, detail design changes, and suppliers
 - Assistance in implementation of design changes
 - Redesign of sub-systems





Inkjet System Integration

■ Printed Electronics Development

- Used for testing a wide range of functional inks, resolutions and curing methods
- Suitable for full-size (18"x24") PCB format



■ Inkjet Ink Development

- Used for testing UV-cured inks
- 2 colours; 2 variable-power UV lamps; Spectra and Xaar printhead modules
- Wet-on-wet or wet-on dry printing

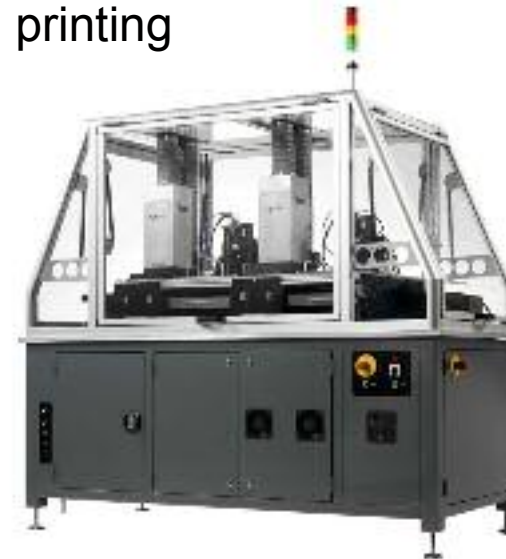

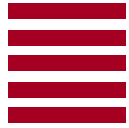

Custom Printing System Development

- Working for you to build **unique high-value systems** developed for your industry.

- Application requirement capture
- Generation of alternative design concepts
- Detailed specification development
- Selection of partners/suppliers
- Detailed design of custom hardware and software
- Integration of the system and detailed testing of both print performance and printer software functionality
- Commissioning and transfer of know-how to your team



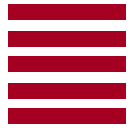

Inkjet Component Design

TTP develops inkjet subsystems for integration into digital printers and inkjet systems

- Header tanks, ink supply controllers (e.g. Xaar's ink supply peripherals)



- Fibre-optic data path systems (e.g. Xaar's "XPCI")

- Meteor – TTP's new universal print controller



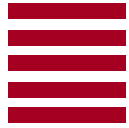

Printer cost reduction / transfer to Asian manufacture

- Working as an extension to your product development resources we can assist with making product lines more competitive
 - 16 years experience of developing printers and transferring to production in China and Malaysia, large manufacturer and component vendor network.
 - Cost-reduction through design innovation and/or supplier changes.
 - Independence allows TTP to give you impartial advice on low cost manufacturers in Asia, Eastern Europe or elsewhere
 - Strong scientific understanding and engineering experience of inkjet permits significant innovation with minimal technical risk



Meteor Universal - Print Controller

First public announcement at
IMI Inkjet Developers Conference
2006 Chicago





Meteor - Universal Print Controller

- Suitable for **all printhead types** and **all digital printers**
- **Low cost** and **expandable** from 1 to very many printheads
- Modularity:
 - 1 PCB [Eurocard size 100mm x 160mm]
 - Supports 6 large greyscale printheads or 6 clusters of 6 small jetting assemblies
 - Tested at 30 MBytes/second (equivalent to 4200sfph @ 600dpi, CMYK, fully variable data,)
 - Indefinitely expandable through adding further modules [with synchronisation to 1/16th pixel between all jetting assemblies]



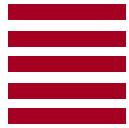

Meteor - Personalities

Any printhead technology is accessible via a dongle or head driver board.

Two initial designs for Summer 2006 are:

■ Greyscale Dongle

- Drives 1 Xaar Leopard / OM318 or Toshiba Tec printhead



dongle



Print head 1



Print head 2



Print head 3

■ Digital pulse-shaping Head Driver Board

- Drives 3 Spectra Nova / Galaxy or 6 Spectra S-class jetting assemblies
- Digital pulse shaping
- Multi-pulse capability
- 40kHz

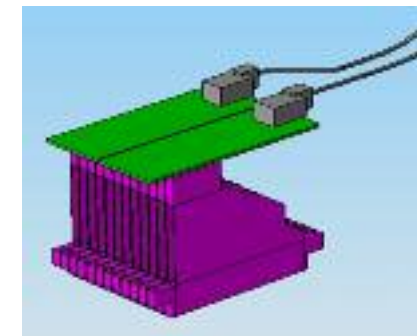

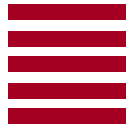

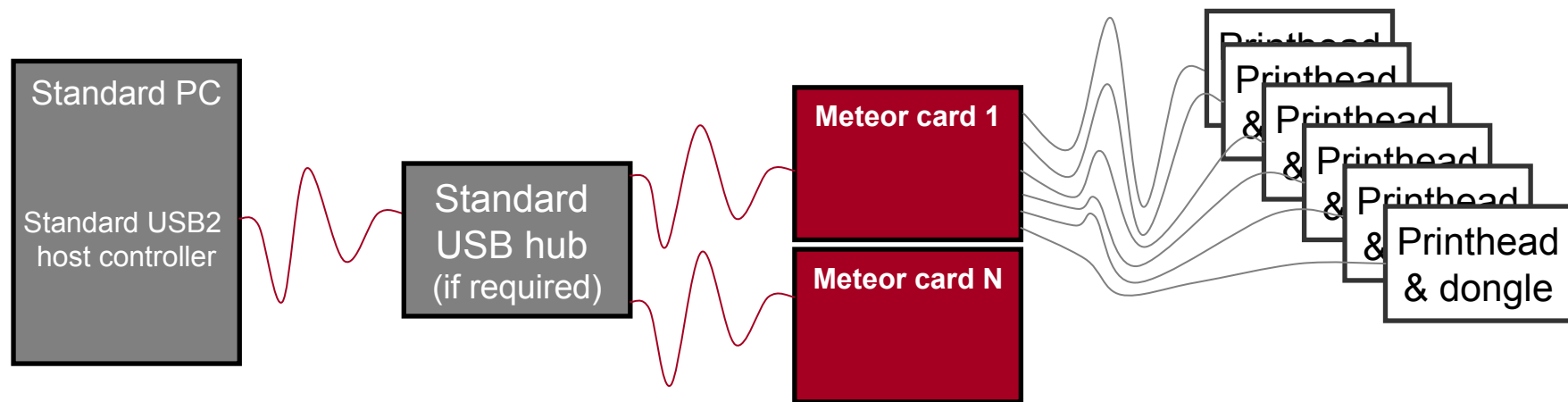

Meteor - Flexibility

- Standard commercially-available cables are used to connect **Meteor** components to produce any necessary configuration

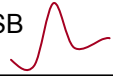

- N **Meteor** cards support 6N printheads or 6N clusters of jetting assemblies
- Peripheral pumps, motors and sensors can be controlled via I/O on each Meteor card, dongle or head driver board

Cable type	Signal type	Max length
USB 	USB2	5x5m (82')
Ethernet Cat 5 	LVDS	>10m (>30')



Meteor - Options

- **Meteor** *design licences* are available from TTP:
 - Whole system design [non-exclusive]
 - with any printhead interface
 - with support for integration into existing printer
 - with optional customisation from USB2 to Firewire, Ethernet or Fibre optic
 - Digital pulse-shaping head driver board design,
 - with support for integration with existing electronics

- **Meteor** *components* are available from TTP:
 - Integration support and software license
 - USB Print Controller Cards
 - Leopard/OM318/ToshibaTec dongles & Spectra Head Driver Boards
 - Other printhead dongles/head driver boards on application

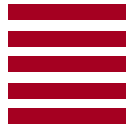

Summary

- **300-strong technology services** group based in Cambridge, UK
- **19-year experience** of working across many industries
- Engineering services available across all types of inkjet product development from the smallest....



...to the largest.

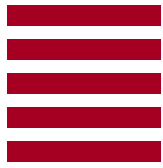

T T P

www.ttp.com

IMI Developers Conference contacts:

john.stanton@ttp.com

phil.duffy@ttp.com

TTP, Science Park, Melbourn, Cambridgeshire
SG8 6EE United Kingdom
Phone +44 (1763) 262626